



MEMS Track Monitoring System Instruction Manual

All efforts have been made to ensure the accuracy and completeness of the information contained in this document. RST Instruments Ltd reserves the right to change the information at any time and assumes no liability for its accuracy.

Copyright © 2019. RST Instruments Ltd. All rights reserved.

Document Number: ICM0071B

Release Date: February 15, 2019

RST INSTRUMENTS LTD.
11545 Kingston St.,
Maple Ridge, BC
CANADA V2X 0Z5

SALES + SERVICE + MANUFACTURING:
604 540 1100 | info@rstinstruments.com
TOLL FREE (USA & Canada) | 1-800-665-5599

REVISION TABLE

Rev.	Revision History	Date	Prepared By	Approved By
A	Initial Release			
B	Format update, added instructions for biaxial monitoring	15-Feb-2019	MP	AP

TABLE OF CONTENTS

1	INTRODUCTION	1
2	SAFETY	3
3	INSTALLATION	3
3.1	Installation Tools and Materials.....	4
3.2	Installing the First Settlement Sensor.....	4
3.3	Installing Subsequent Settlement Sensors.....	6
3.4	Installing the Final Anchor Plate.....	9
3.5	Installing Twist Sensors.....	11
3.6	Biaxial Settlement Sensor.....	12
4	OPERATION	12
4.1	Sign Conventions.....	12
4.1.1	Uniaxial Settlement Sensor and Twist Sensor.....	12
4.1.2	Biaxial Settlement Sensor.....	13
4.2	Uniaxial MEMS TMS.....	14
4.3	Biaxial MEMS TMS.....	15
4.4	Taking Readings.....	15
4.4.1	Initial Readings.....	16
4.4.2	Current Readings.....	16
5	ELECTRICAL CONNECTIONS	16
6	SPECIFICATIONS	18
7	SERVICE AND REPAIR	18

LIST OF FIGURES

Figure 1-1	Overview of a uniaxial MEMS Track Monitoring System with twist sensors.....	2
Figure 3-1	Components of the MEMS TMS.....	3
Figure 3-2	Anchor plate (detail).....	5
Figure 3-3	Extension tube (detail).....	5
Figure 3-4	Connecting the first settlement sensor to the anchor plate.....	6
Figure 3-5	Cutting the extension tube to make sure anchor plate sits on tie.....	7
Figure 3-6	Inserting the extension tube into the telescopic coupling.....	7
Figure 3-7	Connecting the next settlement sensor.....	8
Figure 3-8	Connecting the next sensor (detail).....	8
Figure 3-9	The final anchor plate.....	9
Figure 3-10	Settlement sensor gauge length.....	10
Figure 3-11	Twist sensor gauge length.....	11
Figure 4-1	Uniaxial settlement sensor sign convention.....	12
Figure 4-2	Twist sensor sign convention.....	13
Figure 4-3	Biaxial settlement sensor sign convention, A-axis and B-axis.....	14

Figure 4-4 Biaxial settlement sensor B-axis sign convention	14
---	----

LIST OF TABLES

Table 5-1 Uniaxial/biaxial (analog output) MEMS TMS colour code table.....	17
Table 5-2 Uniaxial/biaxial (digital output) MEMS TMS.....	17
Table 5-3 M12 connectors and digital outputs.....	17
Table 6-1 Environmental specifications.....	18
Table 6-2 Electrical specifications	18
Table 6-3 Mechanical specifications.....	18

LIST OF EQUATIONS

Equation 1 Tilt displacement	14
Equation 2 Axis A – linear displacement	15
Equation 3 Axis B – change in the degree of rotation.....	15

1 INTRODUCTION

RST Micro-Electro-Mechanical Systems (MEMS) Track Monitoring System (TMS) is intended for monitoring settlement and twist of railroad tracks that may be affected by nearby construction activity, such as tunnelling or adjacent excavation, or which are located near hazardous zones, such as potential washout or landslide areas.

A uniaxial TMS consists of bussed settlement sensors mounted longitudinally along the track alignment, typically with a mount spacing of 2 or 3 metres, and one or more bussed twist sensors mounted perpendicularly to the settlement sensors. The settlement and twist sensors are based on the same MEMS devices used in the MEMS Tilt and Inclination Series of products from RST Instruments. The uniaxial TMS with a twist sensor is the most accurate way to measure deflection on two axes.

A biaxial TMS consists of bussed settlement sensors mounted longitudinally along the track alignment, with a mount spacing between 2 and 3 metres. The sensors are capable of measuring movement along two axes. The sensors are based on the same MEMS devices used in RST Instruments' MEMS Tilt and Inclination devices.

All of the sensors in the TMS are fully compatible with the DT2485 datalogger, FlexDAQ dataloggers and the GeoViewer data display and management software.

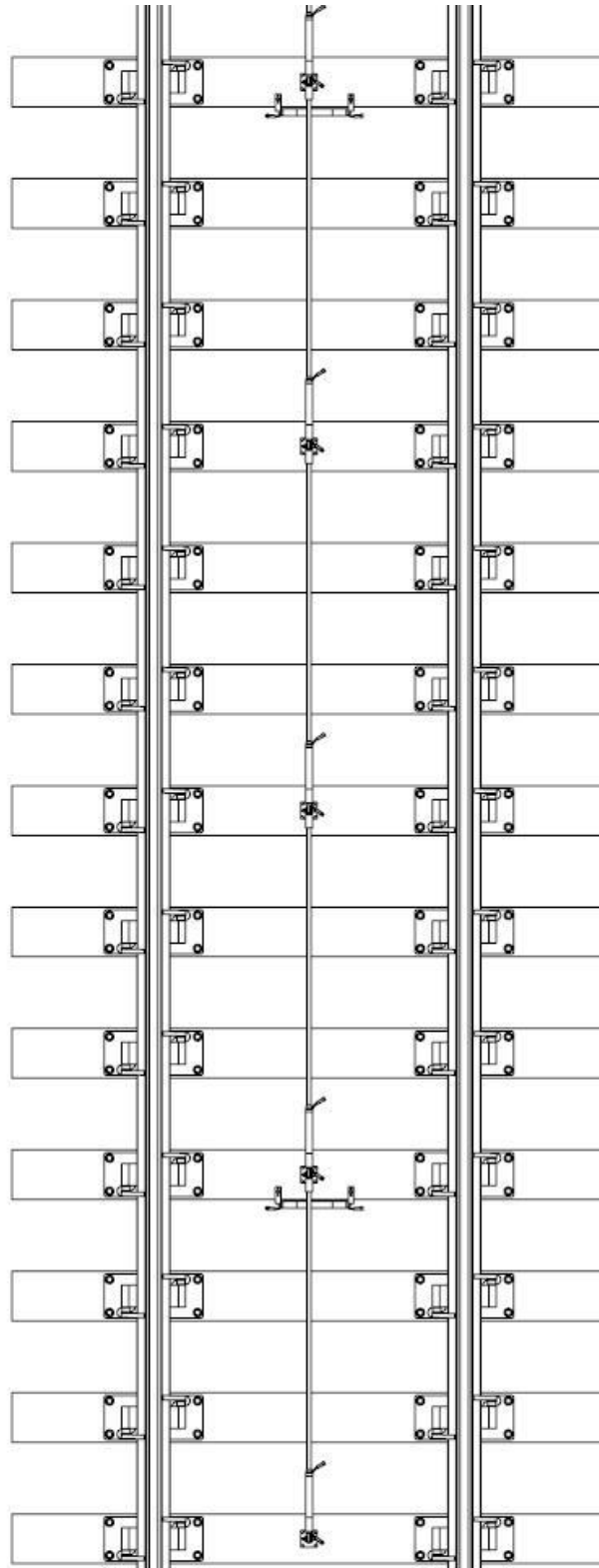

FIGURE 1-1 OVERVIEW OF A UNIAXIAL MEMS TRACK MONITORING SYSTEM WITH TWIST SENSORS

2 SAFETY

Normal safety precautions should be followed and proper personal protective equipment (PPE) should be worn when working in the field with this equipment, including safety glasses and high-visibility clothing.

The installation location may be an active railroad. It is important to obtain the correct permissions in order to access the installation location.

3 INSTALLATION

The following section describes the installation procedure for the MEMS TMS. Individual components of the system are illustrated in Figure 3-1.

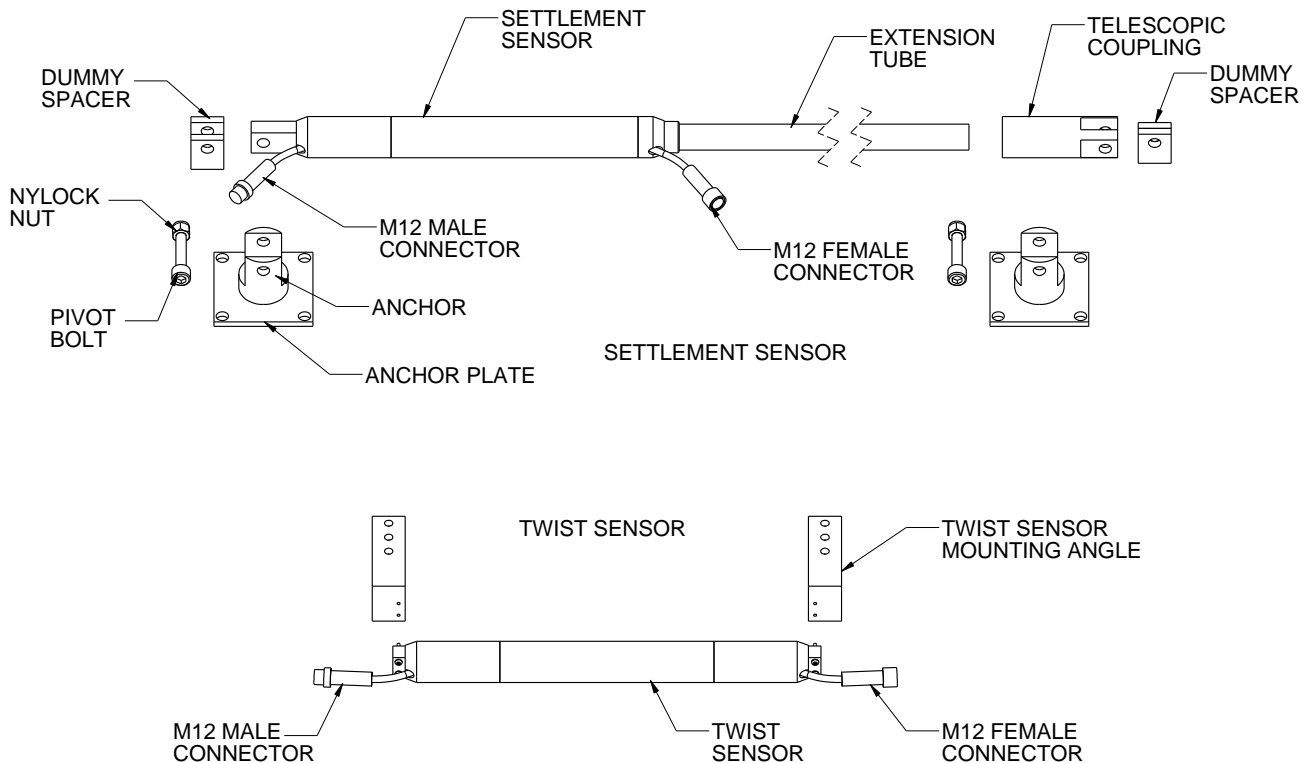

FIGURE 3-1 COMPONENTS OF THE MEMS TMS

3.1 INSTALLATION TOOLS AND MATERIALS

In addition to the standard tool kit, the following tools and materials may be useful:

- Appropriate bolts and washers.
- Lock washers for user-specific installation.
- Clamps.
- Saw with metal cutting blades.
- Metal file.
- Cable ties.
- Cable clamp.

3.2 INSTALLING THE FIRST SETTLEMENT SENSOR

The following steps outline the procedure for installing the settlement sensors:

- 1 Plan the location of all of the sensors in the array.



NOTE: IF POSSIBLE, SENSORS SHOULD BE INSTALLED IN ORDER ACCORDING TO THEIR SERIAL NUMBER TO FACILITATE MAPPING THE DATA. KEEP TRACK OF THE SERIAL NUMBERS AND THEIR LOCATIONS AS THE SENSORS ARE INSTALLED.

- 2 Lay all of the anchor plates (Figure 3-2) and instruments (Figure 3-3) along the track. The extension tubes are used to help space the anchor plates.



CAUTION: ANCHOR PLATES MUST BE PLACED ON TIES. DAMAGE TO THE TIES SHOULD BE TAKEN INTO ACCOUNT PRIOR TO INSTALLATION, AS TIES WITH DAMAGE OR ROT MAY NOT PROVIDE SUFFICIENT SUPPORT FOR THE ANCHOR PLATES.



NOTE: SPACING BETWEEN THE ANCHOR PLATES IS SPECIFIED BY THE USER UPON ORDERING. EXTENSION TUBES AND CABLES ARE CUT TO LENGTH FOR EACH ORDER.

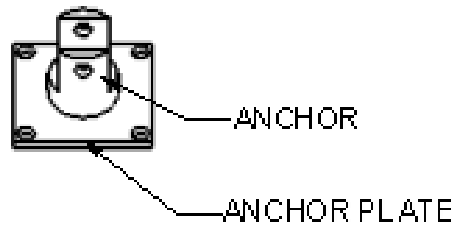

FIGURE 3-2 ANCHOR PLATE (DETAIL)

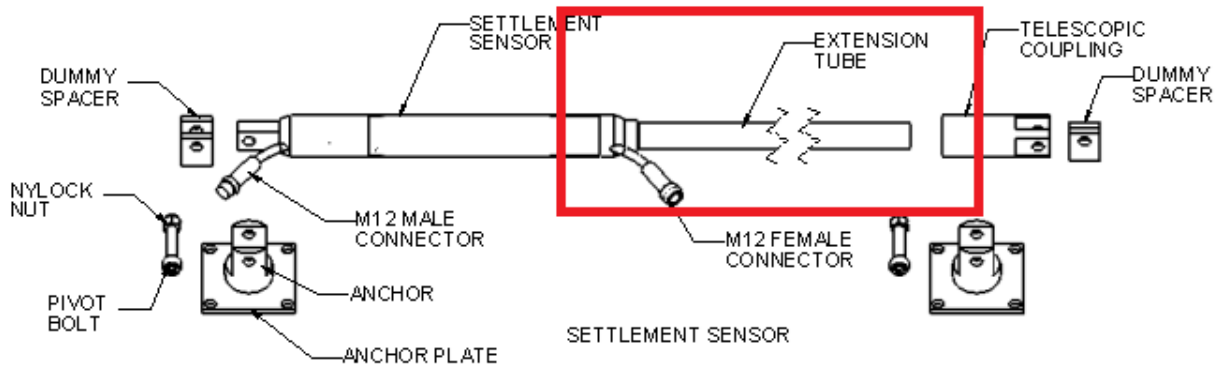

FIGURE 3-3 EXTENSION TUBE (DETAIL)

- 3 Confirm the first anchor plate is properly placed.
- 4 Fix the anchor plate to the rail tie.



CAUTION: THE MATERIAL OF THE RAIL TIE WILL DETERMINE THE METHOD USED TO ATTACH AND FIX THE ANCHOR PLATE. FOR WOODEN TIES, A BOLT AND NUT WILL BE APPROPRIATE. FOR CONCRETE TIES, A CLAMPING METHOD SHOULD BE USED.

- 5 Place the pivot housing adaptor on the end of the first settlement sensor into the groove on the anchor plate, aligning the holes.
- 6 Place a dummy spacer on both sides of the housing adapter, making sure the holes are properly aligned.
- 7 Slide the pivot bolt through the sensor, spacers, and anchor and secure with the Nylock nut (Figure 3-4).



CAUTION: DO NOT OVER TIGHTEN THE BOLT OR NUT, AS THE SENSOR NEEDS TO BE ABLE TO ROTATE.

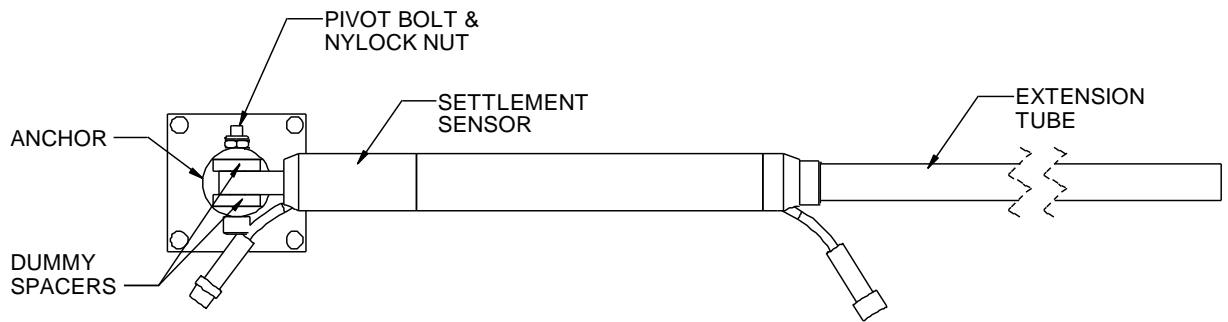

FIGURE 3-4 CONNECTING THE FIRST SETTLEMENT SENSOR TO THE ANCHOR PLATE



NOTE: DUMMY SPACERS ARE ONLY USED ON THE FIRST AND LAST ANCHOR OF THE MEMS TMS.

3.3 INSTALLING SUBSEQUENT SETTLEMENT SENSORS

- 1 Proceed to the next anchor. Review the placement and adjust if necessary.
- 2 Calculate the length of extension tube necessary to ensure the anchor plate sits on a tie.



CAUTION: ANCHOR PLATES MUST SIT ON AND BE SECURED TO A TIE. ANY DAMAGE TO THE TIE SHOULD BE CONSIDERED PRIOR TO INSTALLATION.



CAUTION: IT IS IMPORTANT TO CONSIDER THE AMBIENT TEMPERATURE BEFORE CUTTING THE EXTENSION TUBE. THE TELESCOPIC COUPLING MUST ACCOMMODATE BOTH EXPANSION AND CONTRACTION OF THE TUBE DUE TO CHANGES IN TEMPERATURE. THE EXTENSION TUBE SHOULD BE PUSHED INTO THE TELESCOPIC COUPLING BY 25MM, OR 1".

- 3 Cut the excess length of the extension tube (Figure 3-5) with the saw. As much as possible, ensure the cut is 90° to the length of the extension tube.



CAUTION: DEBURR THE EDGES OF THE EXTENSION TUBE WITH THE METAL FILE AFTER IT HAS BEEN CUT. ENSURE THAT THE EXTENSION TUBE IS ROUND.

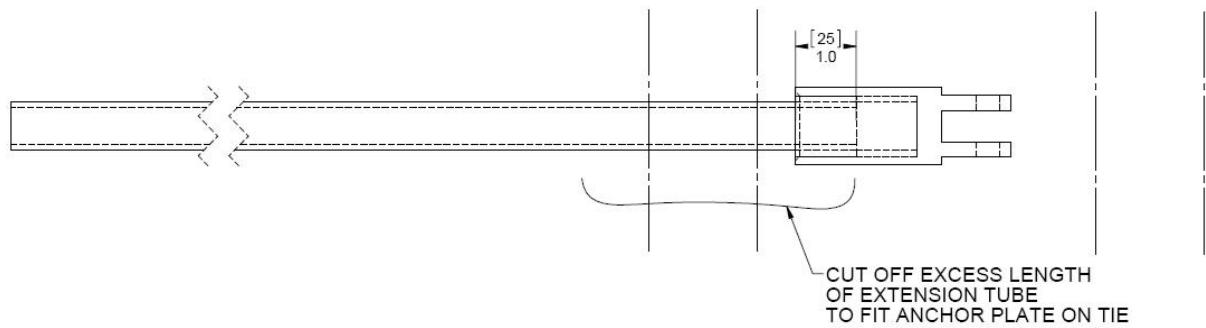

FIGURE 3-5 CUTTING THE EXTENSION TUBE TO MAKE SURE ANCHOR PLATE SITS ON TIE

- 4 Slide the extension tube into the telescopic coupling by 25mm or 1" (Figure 3-6).

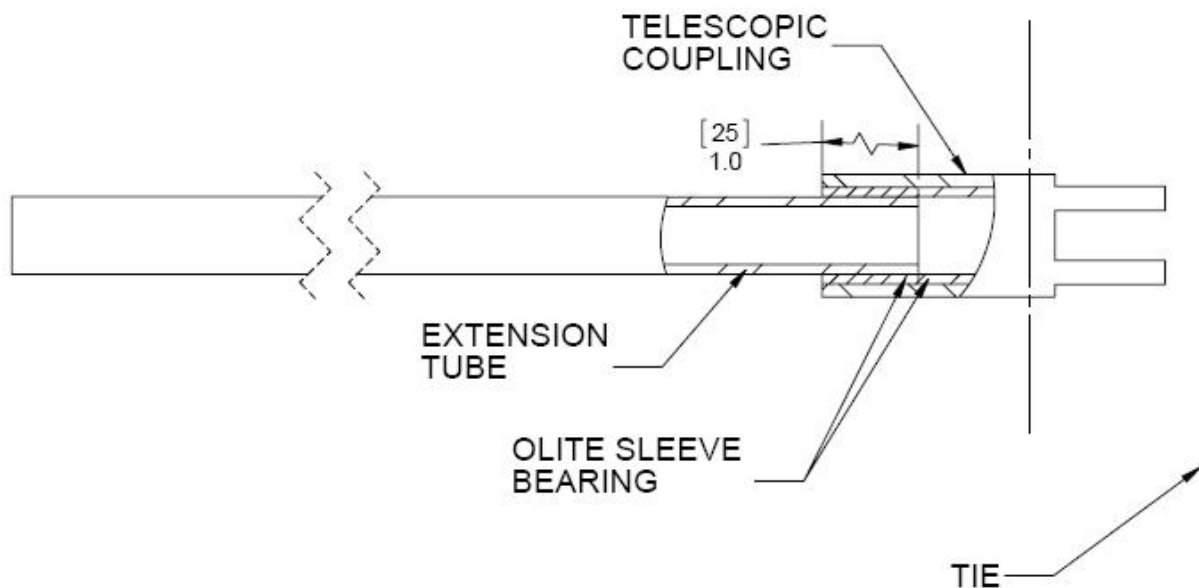

FIGURE 3-6 INSERTING THE EXTENSION TUBE INTO THE TELESCOPIC COUPLING

- 5 Place the telescopic coupling of the first sensor into the next anchor.
- 6 Place the pivot adapter from the second sensor into the anchor.
- 7 Slide the pivot bolt through the anchor, telescopic coupling from the first sensor, and the adapter on the second settlement sensor.
- 8 Lock the pivot bolt with the Nylock nut. See Figure 3-7 and Figure 3-8 for images depicting this connection.



CAUTION: DO NOT OVER TIGHTEN THE BOLT OR NUT, AS THE SENSOR NEEDS TO BE ABLE TO ROTATE.

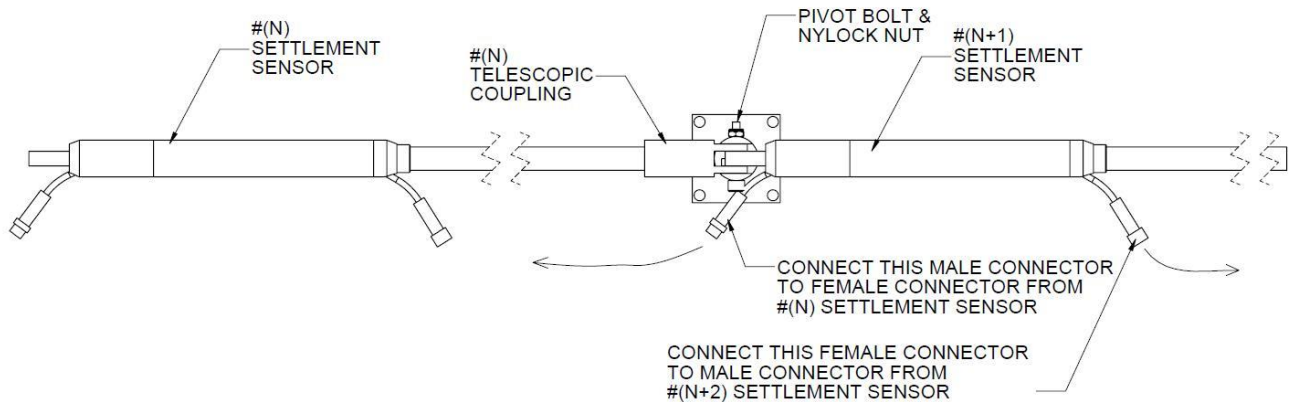

FIGURE 3-7 CONNECTING THE NEXT SETTLEMENT SENSOR

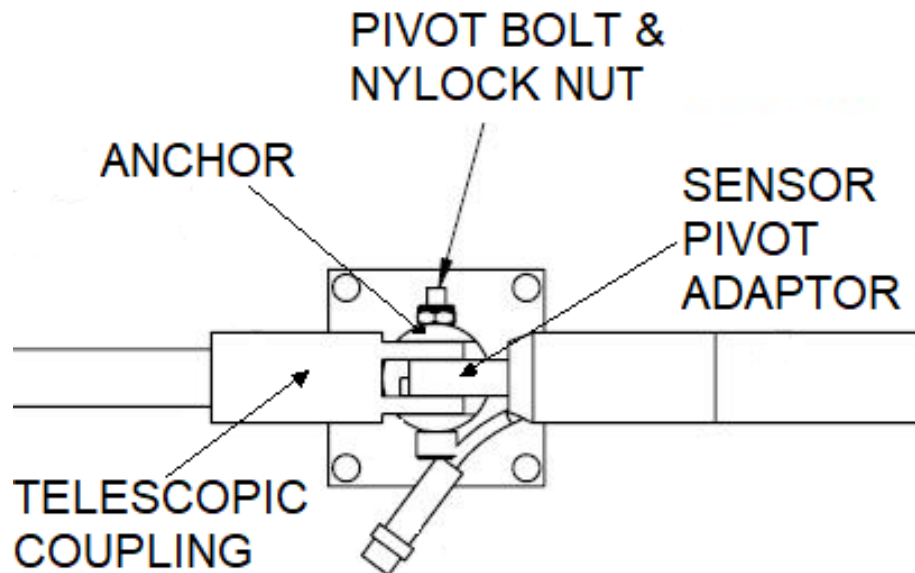

FIGURE 3-8 CONNECTING THE NEXT SENSOR (DETAIL)

- 9 Secure the anchor plate to the tie.



CAUTION: THE MATERIAL OF THE RAIL TIE WILL DETERMINE THE METHOD USED TO ATTACH AND FIX THE ANCHOR PLATE. FOR WOODEN TIES, A BOLT AND WASHER WILL BE APPROPRIATE. FOR CONCRETE TIES, A CLAMPING METHOD SHOULD BE USED.

- 10 Connect the male connector from the first settlement sensor to the female connector from the second settlement sensor. If sections of sensors are separated, a supplied cable extension will be used to connect the sensors.
- 11 If excess cable is present, secure it to the rail ties. A cable clamp is recommended to facilitate installation.



CAUTION: LOOSE OR EXCESS CABLES MAY BE CAUGHT BY A TRAIN AND DAMAGED OR DESTROYED.

12 Repeat steps 1 – 11 until all settlement sensors have been installed.

3.4 INSTALLING THE FINAL ANCHOR PLATE

- 1 Place the telescopic coupling of the last sensor into the final anchor plate.
- 2 Place two dummy spacers to fill the gap in the telescopic coupling (Figure 3-9).



NOTE: DUMMY SPACERS ARE ONLY USED ON THE FIRST AND LAST ANCHOR OF THE MEMS TMS.

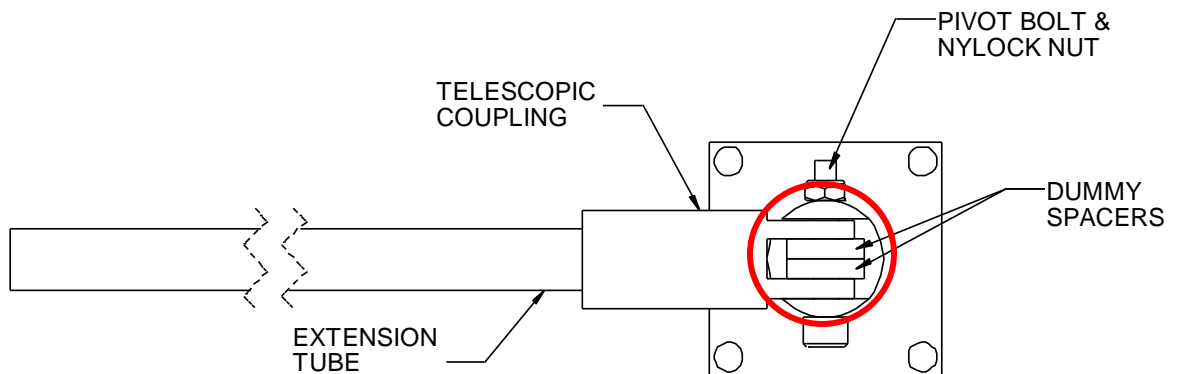

FIGURE 3-9 THE FINAL ANCHOR PLATE

- 3 Slide the pivot bolt through the anchor, telescopic coupling, and the dummy spacers. Lock the pivot bolt into place with the Nylock nut.



CAUTION: DO NOT OVER TIGHTEN THE BOLT OR NUT, AS THE SENSOR NEEDS TO BE ABLE TO ROTATE.

- 4 Loosely tie off excess cable along the extension tube with cable ties.
- 5 Measure and record the gauge length and corresponding serial number for each settlement sensor. Gauge length is the measure from pivot anchor to pivot anchor (Figure 3-10).

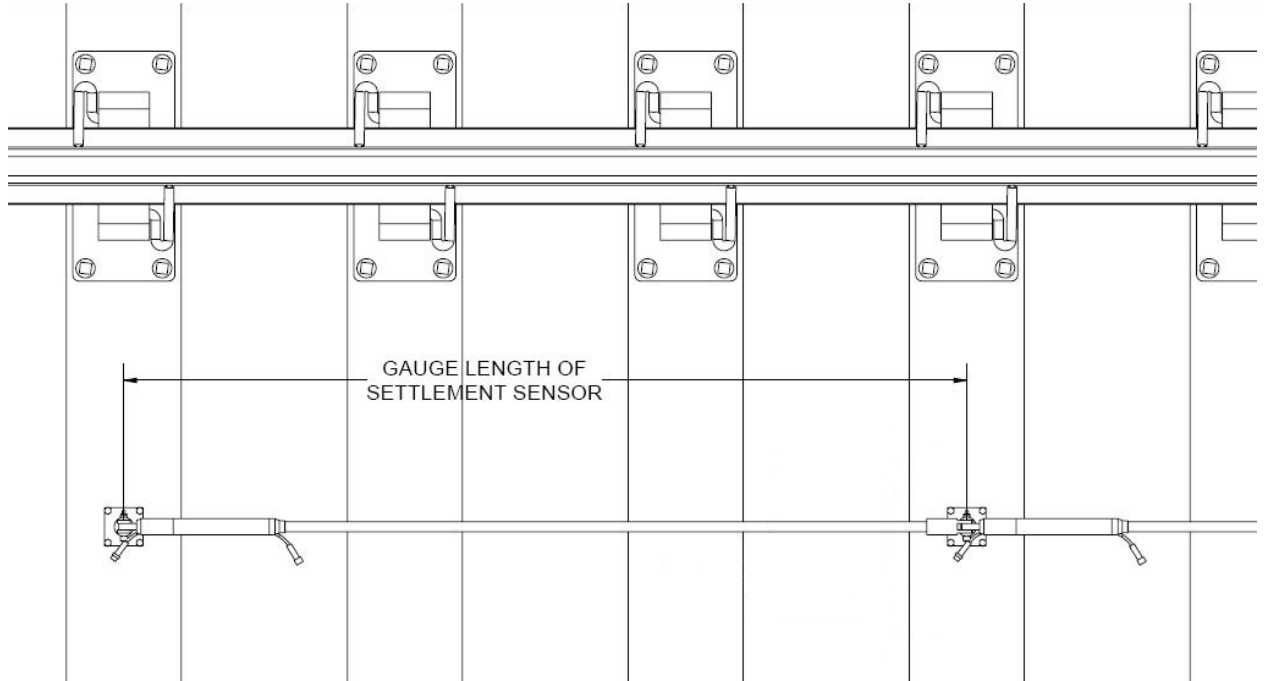

FIGURE 3-10 SETTLEMENT SENSOR GAUGE LENGTH

- 6 Add half of a pipe as a protective cover for the MEMS TMS and sensor cables. This step is optional.

3.5 INSTALLING TWIST SENSORS

If desired, twist sensors can be installed at rail ties perpendicular to settlement sensors. See Figure 3-11.

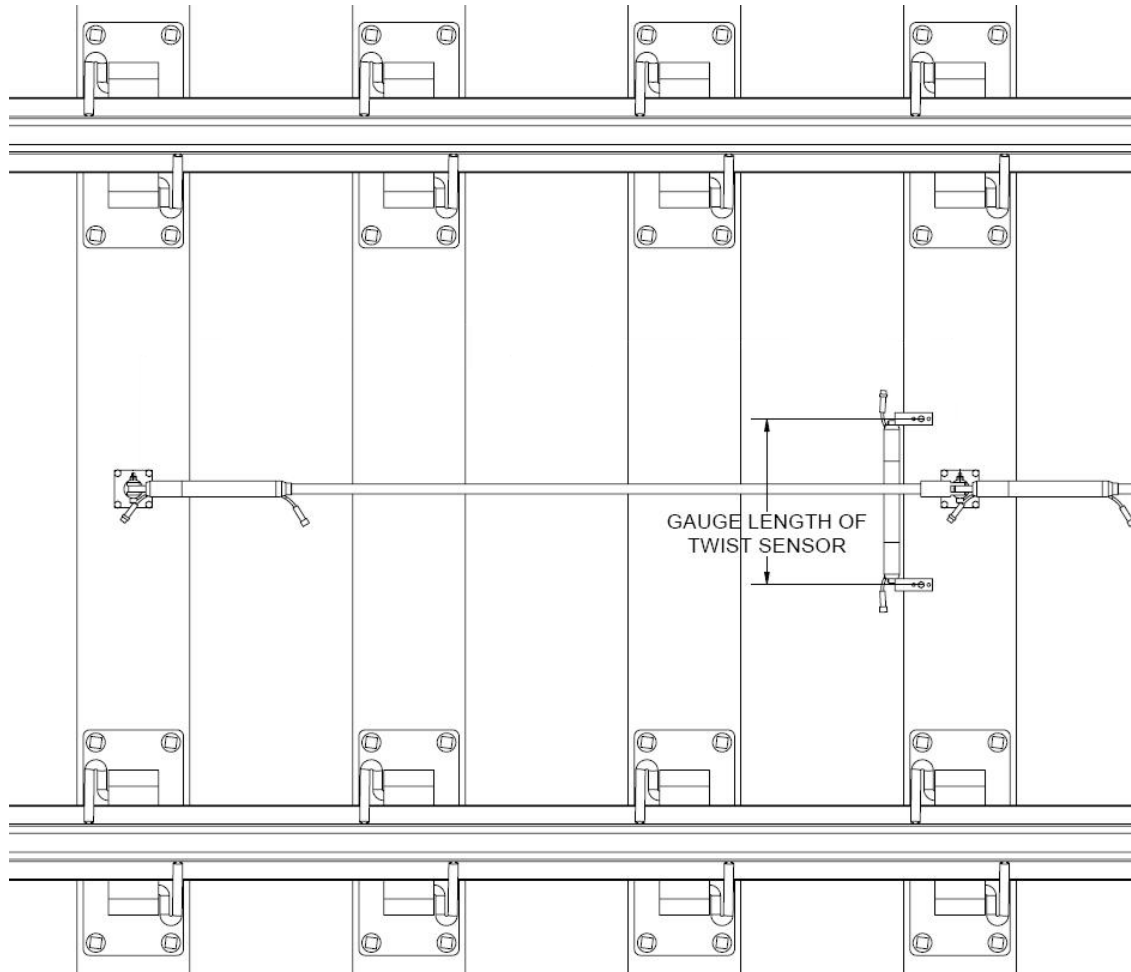

FIGURE 3-11 TWIST SENSOR GAUGE LENGTH

- 1 At the desired location, place the twist sensor perpendicular to the settlement sensor on the same tie.
- 2 Fix the twist sensor mounting angle to the tie.



CAUTION: THE MATERIAL OF THE RAIL TIE WILL DETERMINE THE METHOD USED TO ATTACH AND FIX THE ANCHOR PLATE. FOR WOODEN TIES, A BOLT AND WASHER WILL BE APPROPRIATE. FOR CONCRETE TIES, A CLAMPING METHOD SHOULD BE USED.

- 3 Connect the male connector from the twist sensor to the female connector from the settlement sensor.

- 4 Connect the female connector from the twist sensor to the male connector from the next settlement sensor.
- 5 Tie off excess cable to the anchor.
- 6 Repeat steps 1 – 5 until all twist sensors are installed.
- 7 Measure and record the gauge length and corresponding serial number for each twist sensor. Gauge length for the twist sensor is measured from the mounting bolt of one twist sensor to the mounting bold of the next twist sensor on the mounting angles.

3.6 BIAxIAL SETTLEMENT SENSOR

To install biaxial settlement sensors, follow the instructions outlined in sections 3.2 – section 3.4.

4 OPERATION

The MEMS TMS is fully compatible with RST Instruments' DT logger series. For detailed information on how to operate a specific data logger, please consult the manual for that logger.

4.1 SIGN CONVENTIONS

4.1.1 Uniaxial Settlement Sensor and Twist Sensor

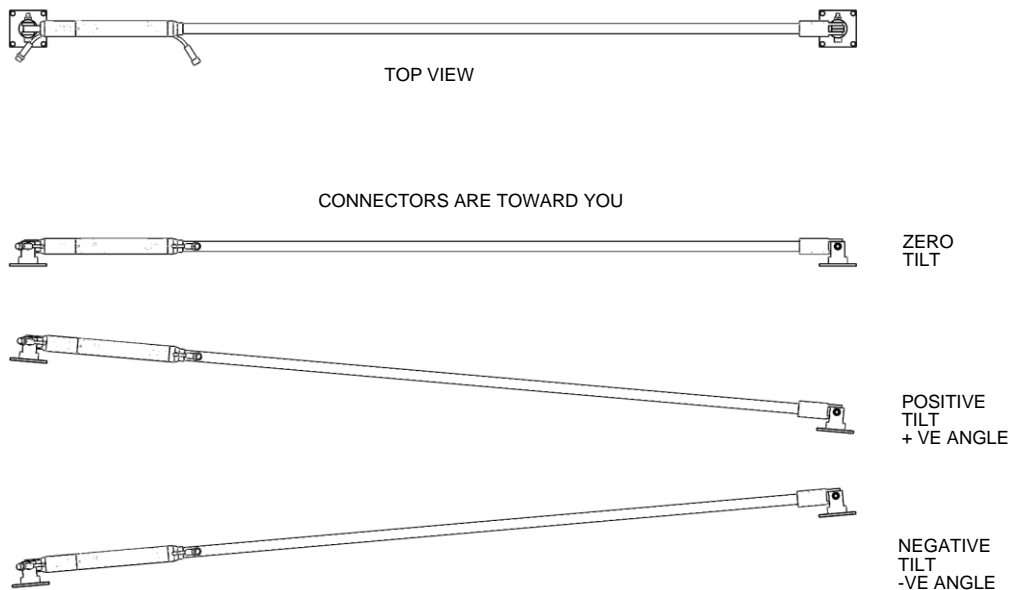

FIGURE 4-1 UNIAxIAL SETTLEMENT SENSOR SIGN CONVENTION

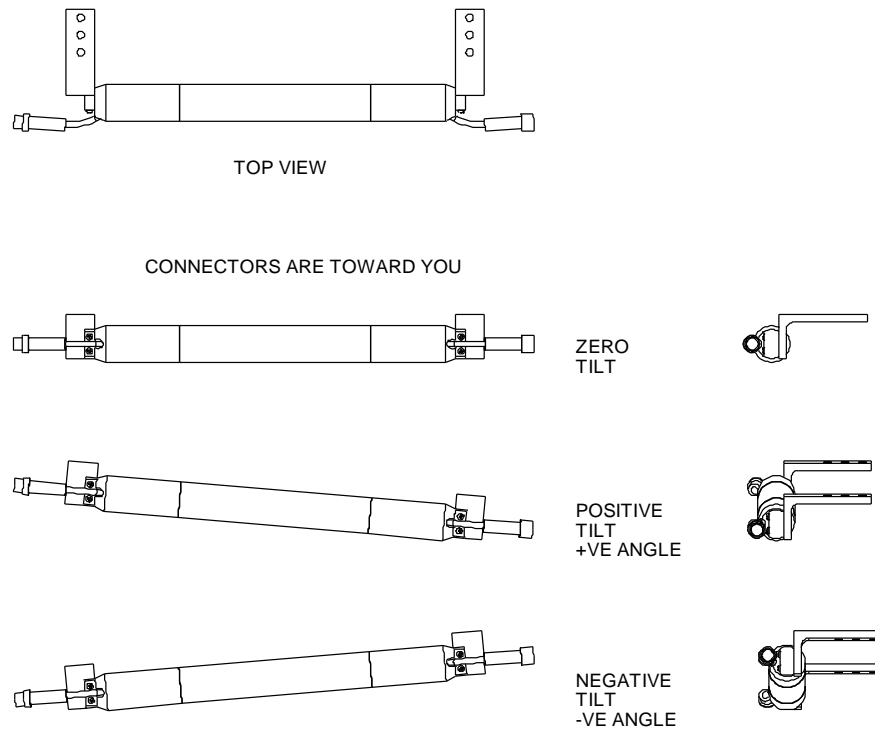

FIGURE 4-2 TWIST SENSOR SIGN CONVENTION

4.1.2 Biaxial Settlement Sensor

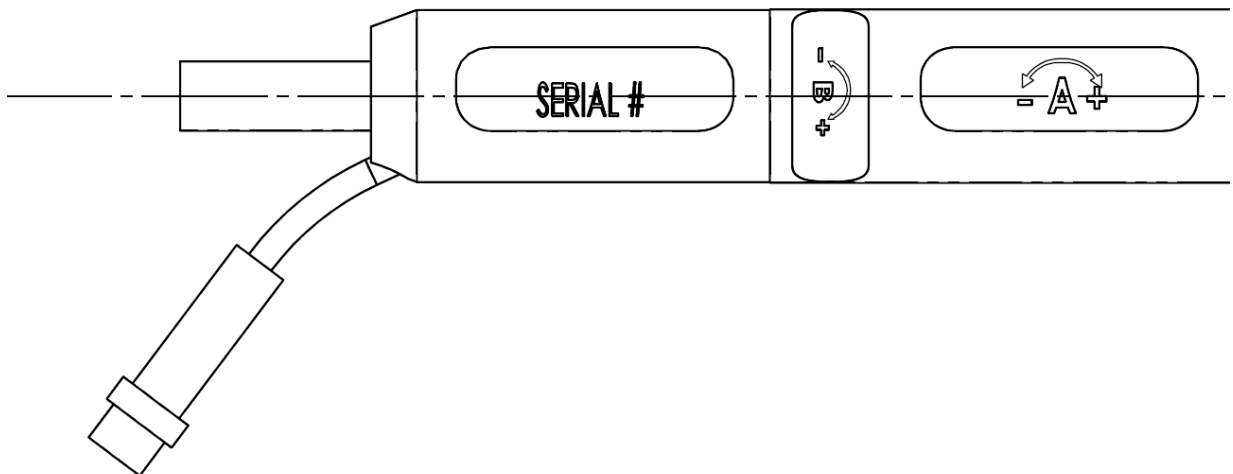
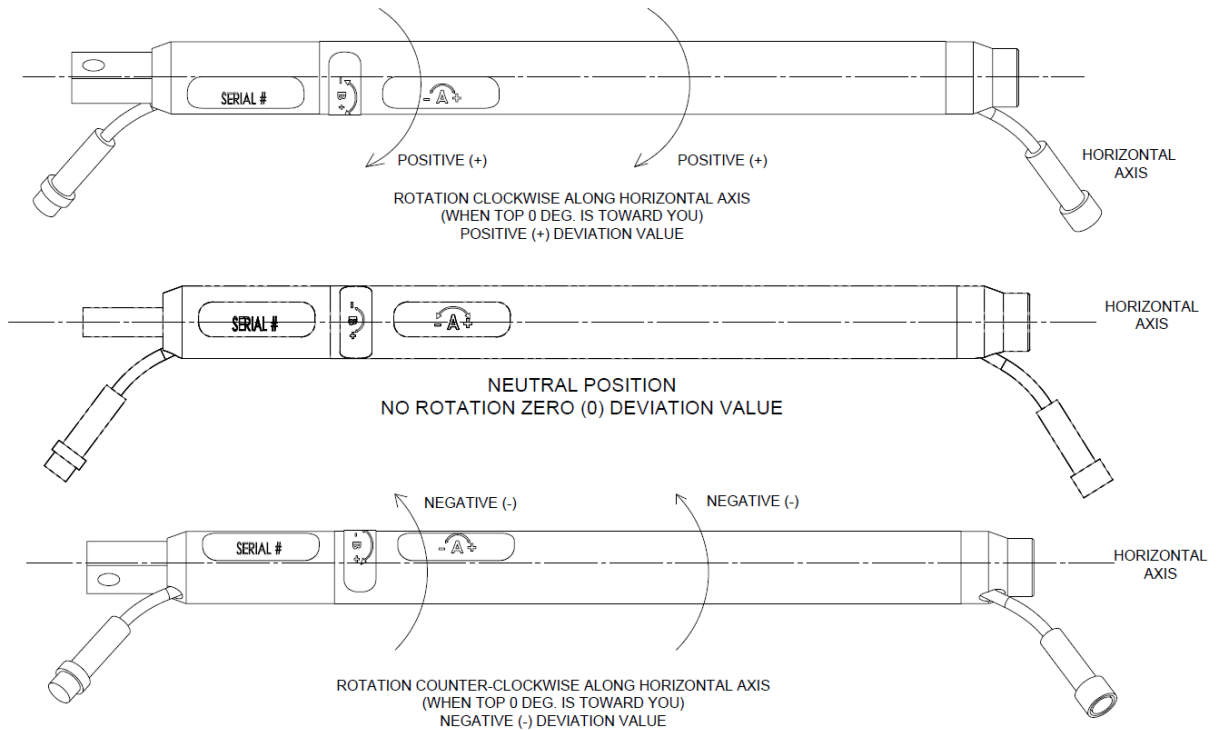

FIGURE 4-3 BIAXIAL SETTLEMENT SENSOR SIGN CONVENTION, A-AXIS AND B-AXIS

FIGURE 4-4 BIAXIAL SETTLEMENT SENSOR B-AXIS SIGN CONVENTION

4.2 UNIAXIAL MEMS TMS

Each MEMS Settlement Sensor and Twist Sensor consist of a $\pm 15^\circ$ sensor mounted inside a $\varnothing 1.25$ " stainless steel housing. Each sensor outputs $\sin \theta$, which is then read by a datalogger or handheld device (see Section 5 for details regarding electrical connections). Any settlement or twist along the track or ties will change the angle output of the sensor. This angle, along with the measured gauge length can be used to calculate the displacement of the track or ties. The displacement can be calculated using Equation 1:

$$\Delta d = L \times (\sin \theta_C - \sin \theta_I)$$

EQUATION 1 TILT DISPLACEMENT

Where,

$\Delta d =$ displacement

$L =$ gauge length of each settlement sensor or twist sensor

$\sin \theta_C =$ Current tilt

$\sin \theta_I =$ Initial tilt

4.3 BIAXIAL MEMS TMS

Biaxial MEMS Track Monitoring Sensors measure linear displacement along the A axis and rotational displacement along the B axis. The sign convention is discussed in Section 4.1.2. Sensors output $\sin \theta$ for each axis, which can then be used to calculate the displacement or rotation of the track.

Along the A, or longitudinal, axis, displacement is a linear measurement that can be expressed by the following equation:

$$\Delta d = L \times (\sin \theta_C - \sin \theta_I)$$

EQUATION 2 AXIS A – LINEAR DISPLACEMENT

Where,

$\Delta d =$ displacement

$L =$ gauge length of each settlement sensor or twist sensor

$\sin \theta_C =$ Current tilt

$\sin \theta_I =$ Initial tilt

On the B axis, the change in the degree of twist can be found using the following equation:

$$\Delta \sin \theta = \sin \theta_C - \sin \theta_I$$

EQUATION 3 AXIS B – CHANGE IN THE DEGREE OF ROTATION

Where,

$\Delta \sin \theta =$ Change in degree of rotation

$\sin \theta_C =$ Current angle of rotation

$\sin \theta_I =$ Initial angle of rotation

Data from the MEMS TMS should be read during quiet times only. Avoid reading data when heavy pile driving or construction activity is present.



CAUTION: ONLY READ DATA FROM THE MEMS TMS WHEN THERE IS NO CONSTRUCTION ACTIVITY PRESENT.

4.4 TAKING READINGS

If possible, sensors should be connected to a datalogger and tested prior to installation to make sure they are fully functional. Once installed, the sensors must be connected to a datalogger and a baseline reading should be taken. This value will be subtracted from subsequent readings to determine the amount of deflection of each sensor. Instructions for taking readings are described in the following sub-sections.



NOTE: DATALOGGERS RETURN SIN θ .

4.4.1 Initial Readings

It is important to take a baseline reading ($\sin \theta_I$) of each sensor immediately after installation, as this will be the reference point from which subsequent displacement measurements will be made.

- 1 Following installation, record the serial number of the individual MEMS Settlement or Twist Sensor.
- 2 Connect the end of each MEMS sensor string to the datalogger, per the wiring diagrams in section 5.
- 3 Power on the datalogger and note the readings.
- 4 Repeat steps 1 – 3 for all MEMS sensor string in the assembly.

4.4.2 Current Readings

To find the degree of tilt ($\sin \theta_C$):

- 1 Record the serial number of the individual MEMS Settlement or Twist Sensor.
- 2 Power on the datalogger and note the readings.
- 3 Repeat steps 1 – 3 for all MEMS sensors in the assembly.

5 ELECTRICAL CONNECTIONS

The following section describes the electrical connections necessary to connect the MEMS TMS to a data logger.

- 1 Under the colour code tables below, look up the lead designations for the type of cable being used. For analog cables, see Table 5-1. For digital cables, see Table 5-2. For M12 connectors, see Table 5-3.
- 2 Under the Electrical Connections Table, make the appropriate lead connections, according to the type of system being used. Keep in mind that both the settlement and twist sensors for the uniaxial MEMS TMS only have an A axis, while the biaxial MEMS TMS has both A axis and B axis.

TABLE 5-1 UNIAXIAL/BIAXIAL (ANALOG OUTPUT) MEMS TMS COLOUR CODE TABLE

Wire Color	MEMS TMS	Data Logger
Red	12V	12V
Black	Ground	Ground
Green	A +	xH
White	A -	xL
Orange	B +	yH
Blue	B -	yL



NOTE: BLUE AND ORANGE WIRES, WHICH MEASURE ROTATION AROUND THE B-AXIS, ARE ONLY USED IN THE BIAxIAL MEMS TMS.

TABLE 5-2 UNIAXIAL/BIAXIAL (DIGITAL OUTPUT) MEMS TMS

Wire Color	MEMS TMS
Red	V +
Black	Ground
Green	A +
White	B -

TABLE 5-3 M12 CONNECTORS AND DIGITAL OUTPUTS

PIN	Wire Color	TMS
1	Brown	12V
2	White	Ground
3	Blue	A +
4	Black	B -

6 SPECIFICATIONS

Specifications of the MEMS TMS are outlined in Table 6-1, Table 6-2 and Table 6-3.

TABLE 6-1 ENVIRONMENTAL SPECIFICATIONS

Operating Temperature	-40°C to +85°C
-----------------------	----------------

TABLE 6-2 ELECTRICAL SPECIFICATIONS

Sensor	MEMS Accelerometer Sensor, uniaxial or biaxial
Range	± 15 Degree Standard
Resolution	± 5 arc sec (± 0.0013 deg) (0.023 mm/m) 10Hz BW
Null Repeatability	±0.0125% F.S. (± 0.002 deg) (0.03 mm/m)

TABLE 6-3 MECHANICAL SPECIFICATIONS

Gauge Length	2 or 3 metres, pre-installation
Housing Diameter	32mm (1 ¼" sensor)
Extension Tube Diameter	19mm (0.75")

7 SERVICE AND REPAIR

The product contains no user-serviceable parts. Contact RST for product service or repair not covered in this manual. See the RST website www.rstinstruments.com for contact information.