



## MEMS Tilt Beam Installation and User Manual

All efforts have been made to ensure the accuracy and completeness of the information contained in this document. RST Instruments Ltd. reserves the right to change the information at any time and assumes no liability for its accuracy.

Copyright © 2022. RST Instruments Ltd. All rights reserved.

**Document Number:** ICM0065C

**Release Date:** 01-December-2023

RST Instruments LTD.  
11545 Kingston St.,  
Maple Ridge, BC  
Canada V2X 0Z5

**SALES + SERVICE +MANUFACTURING**

604-540-1100 | [info@rstinstruments.com](mailto:info@rstinstruments.com)

Toll Free (USA & Canada) 1-800-665-5599

[www.rstinstruments.com](http://www.rstinstruments.com)

## TABLE OF CONTENTS

<b>1</b>	<b>OVERVIEW .....</b>	<b>4</b>
1.1	Intended Audience.....	5
1.2	Icons and Conventions Used In This Guide .....	5
<b>2</b>	<b>INSTALLATION.....</b>	<b>5</b>
2.1	Required Tools and Components .....	5
2.2	Installation Guidelines.....	5
2.3	Install Anchor Kit.....	5
2.4	Install a Single MEMS Tilt Beam.....	7
2.5	Install Multiple MEMS Tilt Beams.....	8
<b>3</b>	<b>OPERATION .....</b>	<b>10</b>
3.1	Electrical Connections .....	10
3.2	Sign Conventions.....	11
3.3	Calculation.....	11
3.4	Take Readings .....	12
	3.4.1 Take Initial or Baseline Reading .....	12
	3.4.2 Take Current Readings.....	12
<b>4</b>	<b>PRODUCT SPECIFICATIONS .....</b>	<b>13</b>
<b>5</b>	<b>SERVICE, REPAIR AND CONTACT INFORMATION .....</b>	<b>14</b>

## LIST OF FIGURES

Figure 1: MEMS Tilt Beam .....	4
Figure 2: MEMS Tilt Beam Components View .....	5
Figure 3: MEMS Tilt Beam Horizontal & Vertical Concrete Anchor Orientation ..	7
Figure 4: MEMS Tilt Beam Mounting Orientation Options.....	8
Figure 5: Single Tilt Beam Orientation .....	9
Figure 6: Single Tilt Beam Bolting Diagram .....	10
Figure 7: Multiple Tilt Beams Installation in Succession.....	11
Figure 8: Multiple Tilt Beams Orientation .....	11
Figure 9: Multiple Tilt Beam Placement Reference .....	12
Figure 10: Multiple Tilt Beams Bolting Diagram – Stage 1 .....	12
Figure 11: Multiple Tilt Beams Bolting Diagram - Stage 2.....	15
Figure 12: Multiple Tilt Beams Directional Reading .....	19
Figure 13: Tilt Beam Data Interpretation.....	24

## LIST OF TABLES

Table 1: M12 Connector Wiring Code.....	10
Table 2: Digital Output for Tilt Beam.....	10

**REVISION HISTORY**

Rev.	Revision History	Date	Prepared By	Approved By
A	Initial Release	October 22, 2008	TW	BK
B	Electrical connection changed	May 10, 2010	TW	BK
C	Sensor changed, Specifications and electrical connection updated. Added RSTAR Affinity Data Logger to Required Tools and Components. Added note regarding drill bit size, enlarged figures for visibility, reworded multiple tilt beams installation section and added step-by-step installation diagrams, added nylon bushing to bolting diagrams, added note about Field PC2, Digital Tilt Bus software and NAUTIZ for readout.	December 01, 2023	TW / SM	CA

# 1 OVERVIEW

RST's Micro-Electro-Mechanical Systems (MEMS) Tilt Beams measure differential tilt in two axial planes movements in structures and consist of a MEMS sensor mounted on a rigid, fiberglass beam. The beam is mounted on anchor bolts set into the structure. Corresponding MEMS Tilt Beam (vertical or horizontal) can be installed on any structure, such as a wall, floor, or ceiling, individually or by joining together lengths of beams and are extremely accurate in generating movement profiles over long distances.

Readings are taken with a manual readout by connecting at the end of the cable linking all the bussed beams, or with a data logger at a remote monitoring station.

Unlike electrolytic sensors which have high coefficients of thermal sensitivity and require precise leveling on structures, MEMS sensors have excellent zero and full-scale stability and do not require precision sensor zeroing.

A typical Tilt Beam system includes the following:

- MEMS Tilt Beam(s)
- Anchor kit(s)
- Extension cable(s) (as needed and can be ordered separately)
- Data logger or readout instrument (can be ordered separately)



Figure 1: MEMS Tilt Beam

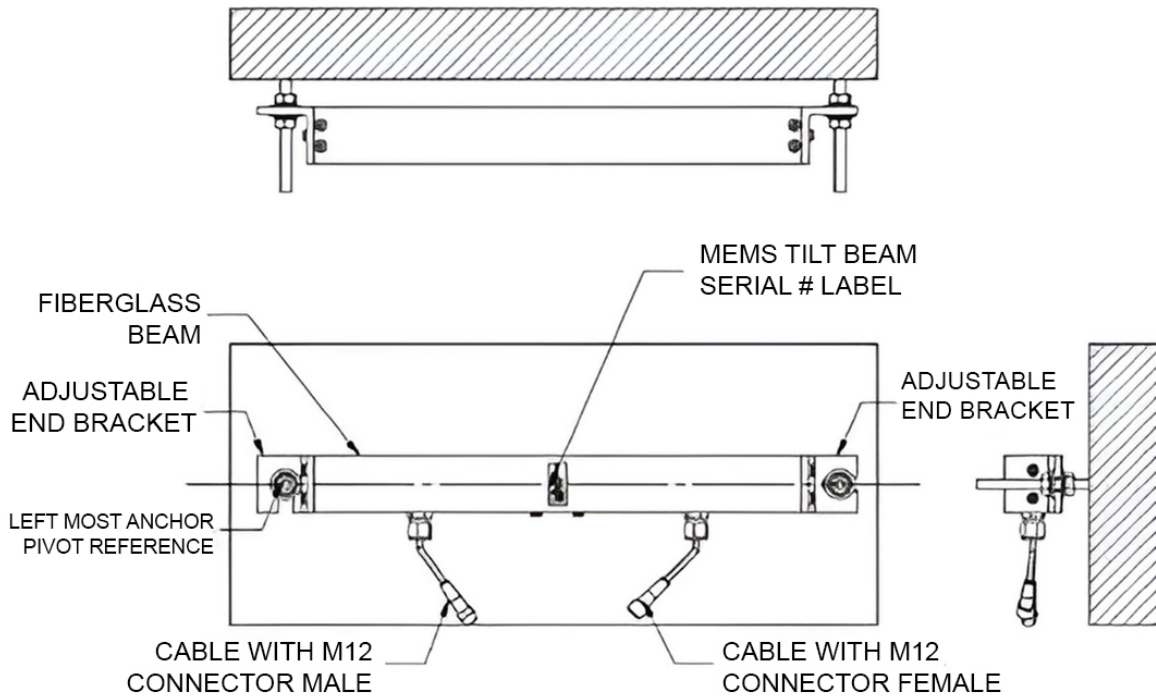

Figure 2: MEMS Tilt Beam Components View



**NOTE:** An IPI connector can optionally be used instead of an M12 connector. Order from RST Instruments.

## 1.1 INTENDED AUDIENCE

This guide is for the personnel responsible for installing or using an RST MEMS Tilt Beam.

## 1.2 ICONS AND CONVENTIONS USED IN THIS GUIDE

This guide uses the following icons to call attention to important information.

---

 **NOTE:** This icon appears to highlight specific non-safety related information.

---

# 2 INSTALLATION

## 2.1 REQUIRED TOOLS AND COMPONENTS

Before installing a MEMS Tilt Beam, make sure to have the following components and tools:

- anchor kit or kits, each kit has two 10 mm SS anchors, four Belleville washers, four nylon washers, two nylon bushing, four 10mm SS nuts,
- Phillips screwdriver
- Two 16 mm wrench
- Level (optional)
- DT2485, RSTAR Affinity Data Logger and/or FlexDAQ Data Logger

---

 **NOTE:** Drill bit size can be obtained from anchor manufacturer.

---

## 2.2 INSTALLATION GUIDELINES

When determining the installation location for the MEMS Tilt Beam, make sure the location will allow the MEMS Tilt Beam end brackets to be secured to a relatively flat and rigid structure or surface that is free of vibration.



**CAUTION:** Avoid installing in areas of rapid or extreme changes in temperature, such as in direct sunlight or near heating or cooling equipment. Use a sunshade and/or external insulation if the unit is exposed to direct sunlight.

---

## 2.3 INSTALL ANCHOR KIT

To install an anchor kit, complete the following steps:

1. Install the anchors at a distance equal to the length of the tilt beam's brackets.
2. Install the anchors as horizontal or vertical as possible. Use a level if necessary.

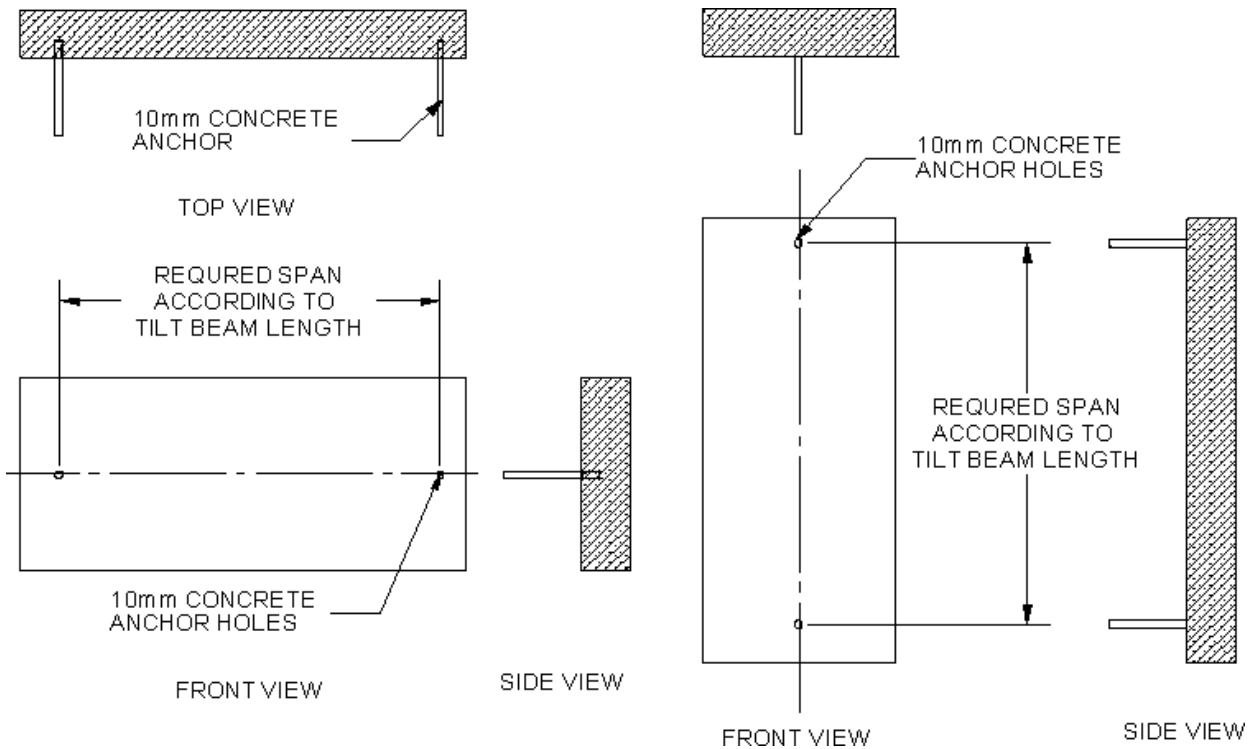

Figure 3: MEMS Tilt Beam Horizontal and Vertical Concrete Anchor Orientation

---

→ **NOTE:** Always mount the sensors on a flat, vertical surface.

---

3. Make sure the anchors protrude horizontally, in all planes, from the structure and not necessarily perpendicular to the structure.



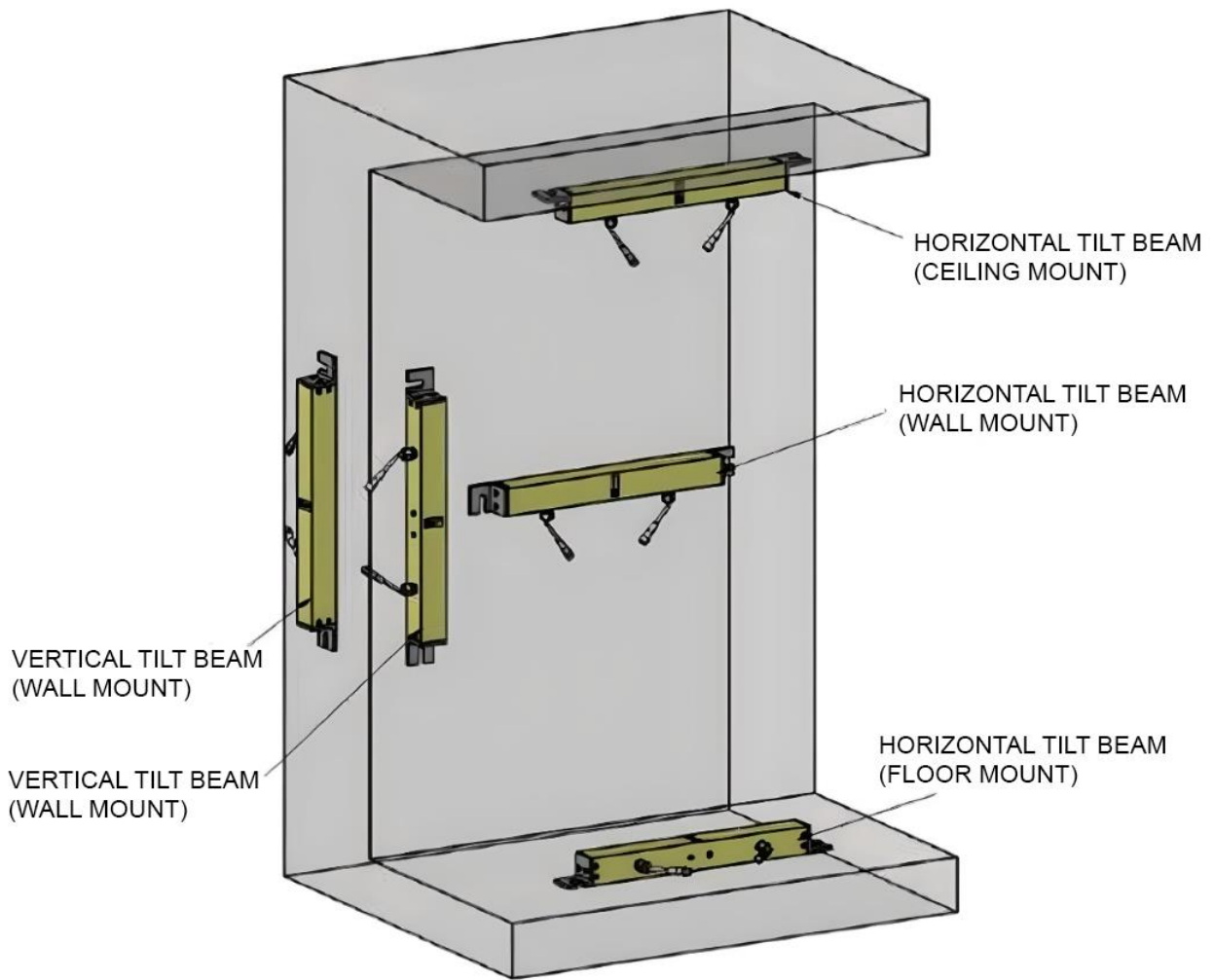

Figure 4: MEMS Tilt Beam Mounting Orientation Options

4. Allow the anchors to set before mounting the tilt beams.

---

→ **NOTE:** If using resin or grout, allow to set based on manufacturer's curing duration.

---

## 2.4 INSTALL A SINGLE MEMS TILT BEAM

To install one MEMS Tilt Beam, complete the following steps:

1. Determine the installation location and orientation. Refer to [Figure 4](#) for mounting orientation options.

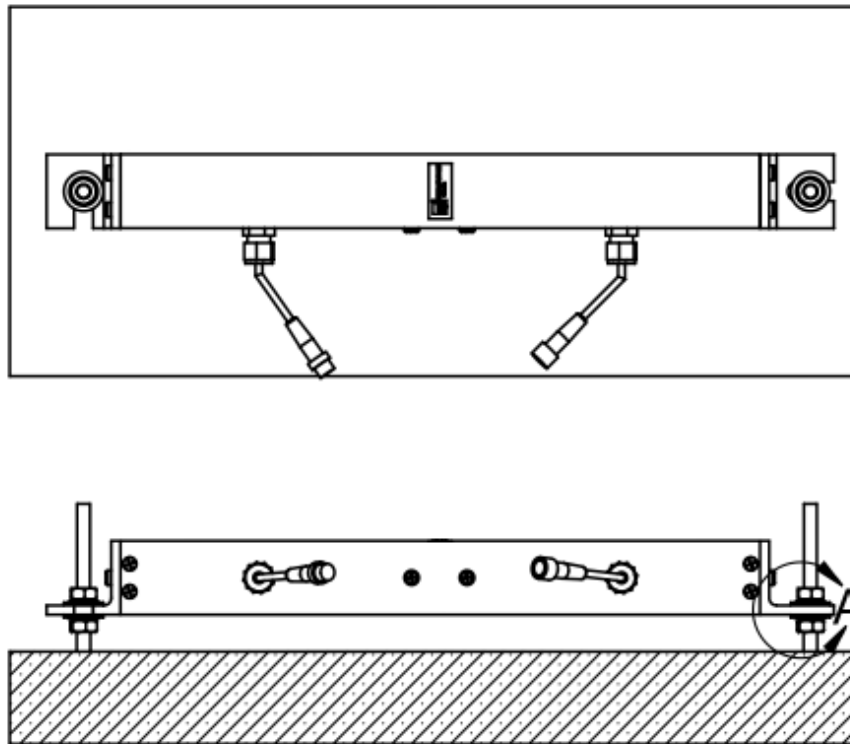

Figure 5: Single Tilt Beam Orientation

- Referring to the bolting diagram in Figure 6, follow steps 3 – 9:

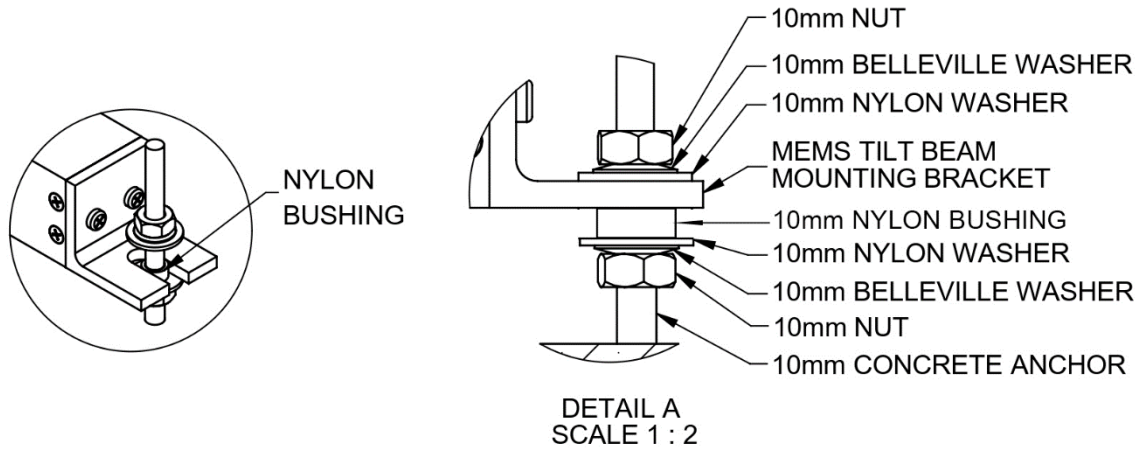

Figure 6: Single Tilt Beam Bolting Diagram

- Thread a 10 mm nut onto each anchor approximately 1 to 2 cm from the surface. Ensure the nuts are leveled with each other.
- Place a Belleville washer over each anchor.
- Place a nylon washer and nylon bushing over each anchor.
- Slide the MEMS Tilt Beam onto the nylon bushings.
- Place a nylon washer and then a Belleville washer over each anchor.
- Thread a 10 mm nut into each anchor. Tighten by hand.



**NOTE:** For a single beam installation where two Belleville washers are used per anchor, turn the nut two to three wrench flats or 120° to 180°.

- Make sure the tilt beam is horizontal or vertical, based on installation orientation.

## 2.5 INSTALL MULTIPLE MEMS TILT BEAMS



**NOTE:** You can install multiple tilt beams either by:

- Installing the odd beams first, followed by the even beams.

**OR**

- Installing the beams one at a time in succession. Referring to Figure 7, install beam A, followed by beam B and beam C:

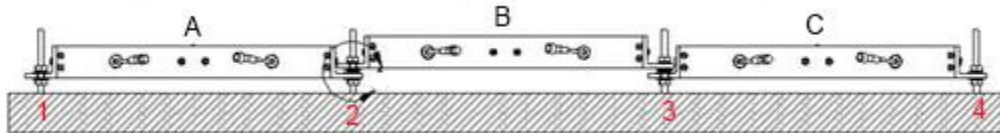

Figure 7: Multiple Tilt Beams Installation in Succession

If the installation is performed correctly, the odd beams will be positioned below the even beams (beam B is fixed above beam A and C, on anchors 2 and 3 respectively).

In either case, multiple tilt beams must be staggered as shown in

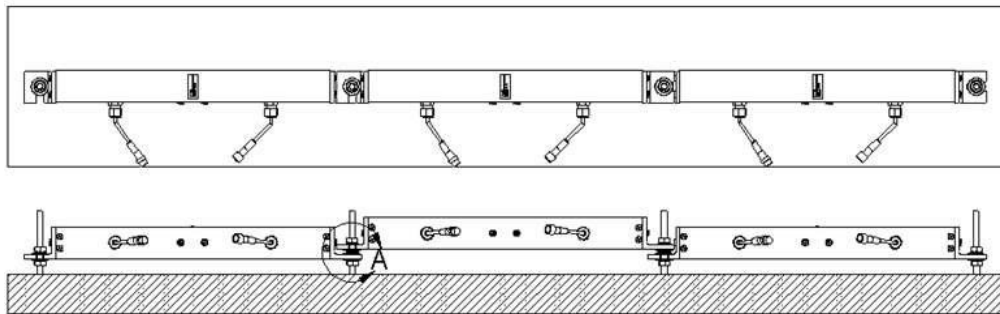

Figure 8: Multiple Tilt Beams Orientation

To install multiple MEMS Tilt Beams, complete the following steps while using Figure 9 and Figure 10 as reference:

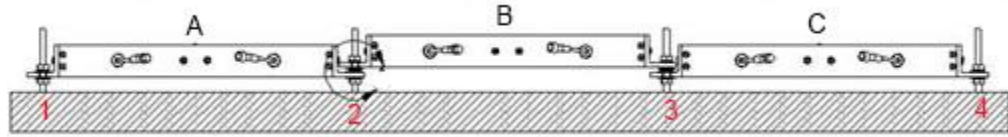

Figure 9: Multiple Tilt Beam Placement Reference

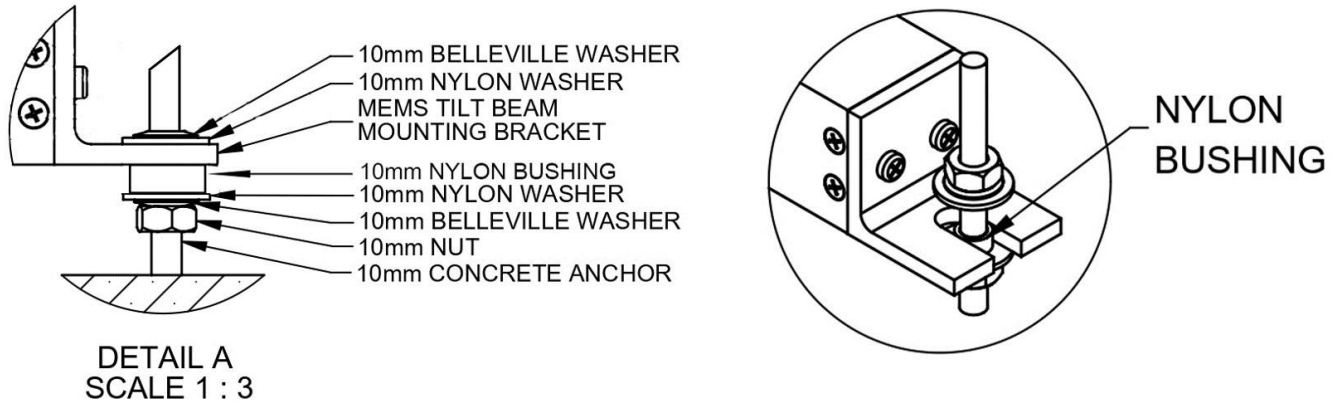
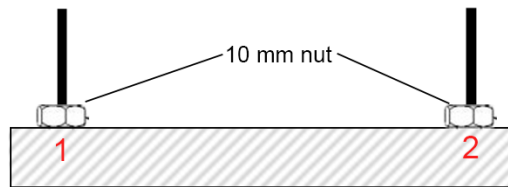
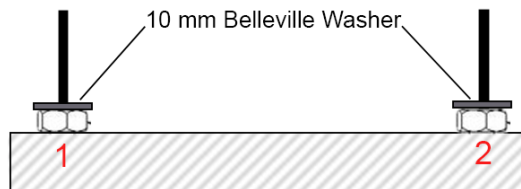

Figure 10: Multiple Tilt Beams Bolting Diagram – Stage 1

1. Determine the installation location and orientation for all tilt beams. Refer to Figure 4 for mounting orientation options. Fix the anchors as required.
2. Thread a 10 mm nut onto the first and second anchors until they reach the desired position, ensuring the nuts are level with each other.



3. Place a Belleville washer each on top of the 10 mm nuts placed in the previous step.



4. Place a nylon washer over each of the Belleville washers.

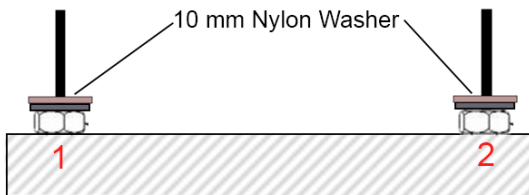

5. Place a nylon bushing over each of the nylon washers.  
The nylon bushing slides onto the anchors to occupy the slot for the mounting brackets.

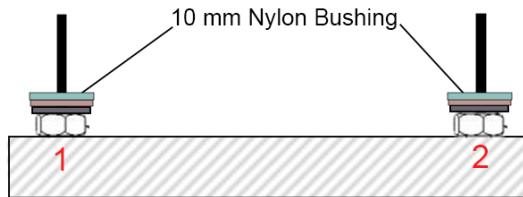

6. Slide the first MEMS Tilt Beam over the nylon bushings.

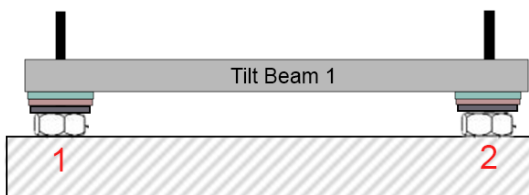

7. Place a nylon washer over the tilt beam on the first and second anchors each.

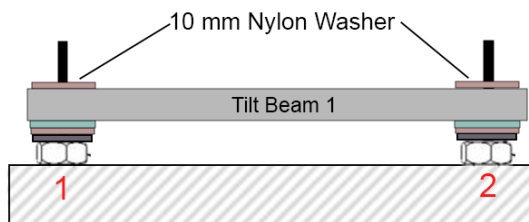

8. Place a Belleville washer over each nylon washer.



9. Thread a 10 mm nut into the first anchor only. Tighten the nut two to three wrench flats or  $120^\circ$  to  $180^\circ$ .

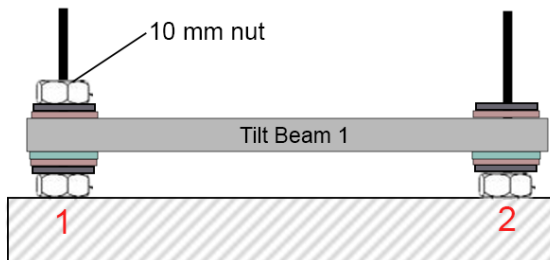

→ **NOTE:** Make sure the tilt beam is horizontal or vertical (based on installation orientation).  
For a double beam installation, where four Belleville washers are used per anchor, turn the nut four to five wrench flats or  $240^\circ$  to  $300^\circ$ .

10. Thread a 10 mm nut onto the third anchor.

→ **NOTE:** Position the nut so that the next beam will be parallel to the previously installed beam.

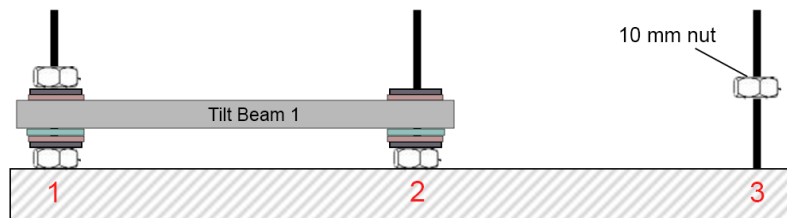

- Place a Belleville washer, a nylon washer, and a nylon bushing on top of the nut that was threaded onto the third anchor.

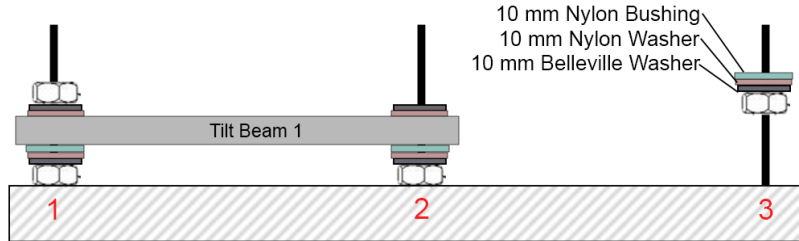

- Place a Belleville washer, a nylon washer, and a nylon bushing on the second anchor, while referring to the bolting diagram in Figure 11. for bolting diagram.

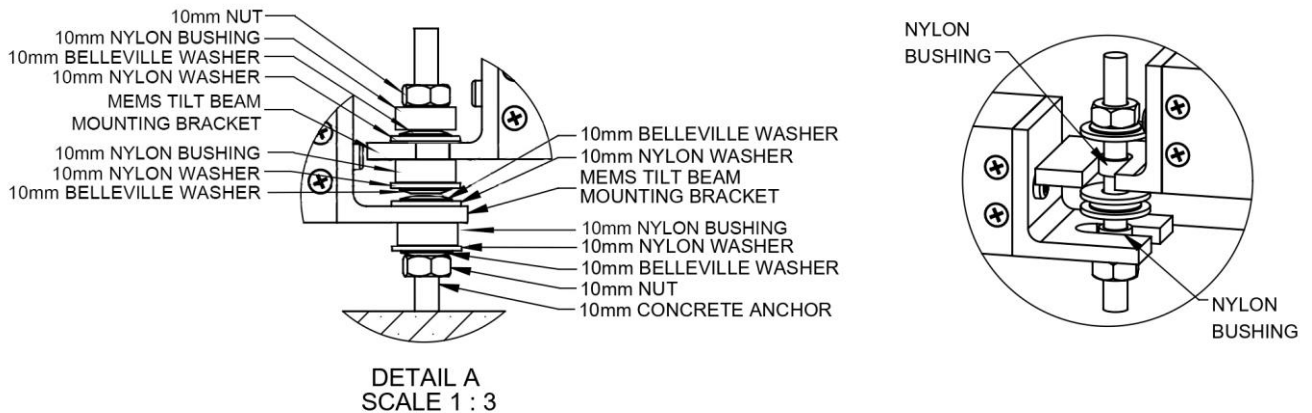
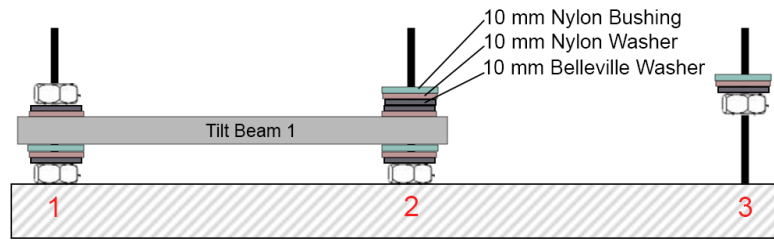
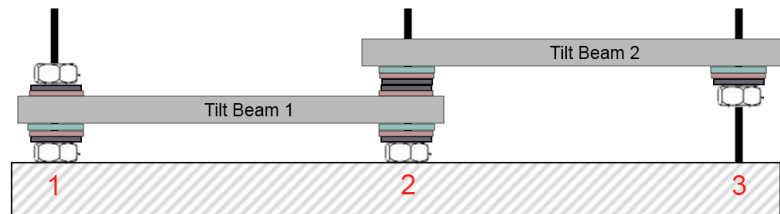

Figure 11: Multiple Tilt Beams Bolting Diagram - Stage 2



13. Slide the second MEMS Tilt Beam onto the second and third anchors.

→ **NOTE:** Adjust the nut on the third anchor until the second beam is parallel to the first beam.



14. Place a nylon washer, followed by a Belleville washer on the second and third anchors.

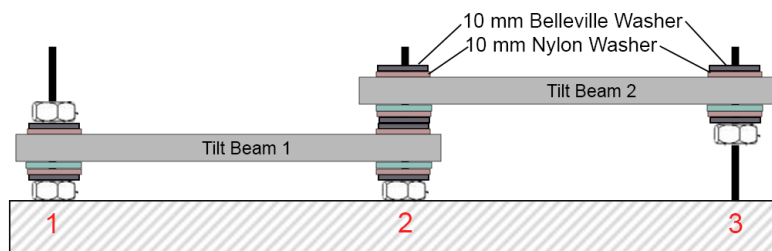

15. Place a nylon bushing on the second and third anchors.

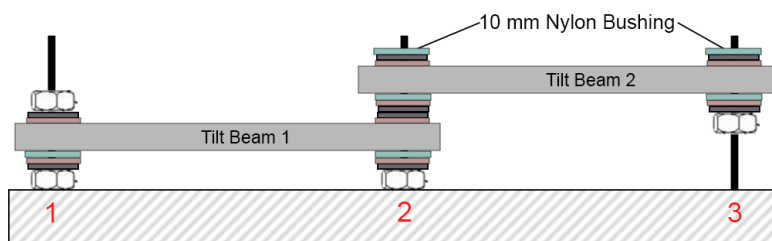

16. Thread a 10 mm nut into the second anchor. Tighten by hand.

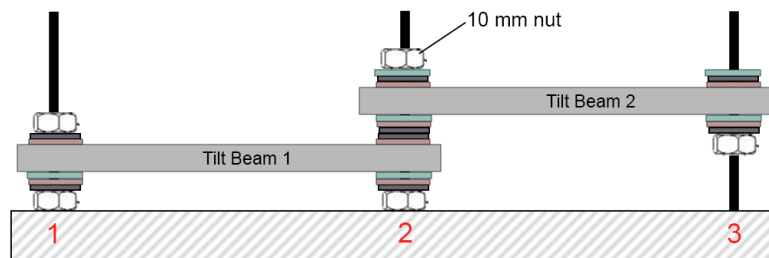

17. Ensure that the tilt beam is horizontal or vertical (based on installation orientation).
18. Tighten the nut four to five wrench flats or 240° to 300°.
19. To add additional Tilt Beams, repeat steps 11 to 19.



**NOTE:** While repeating steps 11 to 19 to add additional beams, increase anchor references by 1, i.e., by step 11, the third anchor would be the fourth anchor.

---

### 3 OPERATION

#### 3.1 ELECTRICAL CONNECTIONS

RST's MEMS Tilt Beams are fully compatible with RST's Affinity Logger, DT2485 and/or FlexDAQ Data Logger. For information on operating a specific data logger, refer to the logger's instruction manual.

	Receptacle	Colour	Plug	Colour
Voltage +	1	Brown	1	Brown
Ground	2	White	2	White
RS485 A+	3	Blue	3	Blue
RS485 B+	4	Black	4	Black

Table 1: M12 Connector Wiring Code

#### RECEPTACLE



#### FACE VIEW

#### PLUG

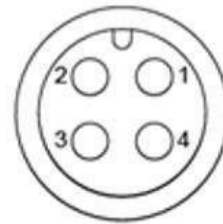

#### FACE VIEW

Wire Color	MEMS Tilt Beam
Brown	V +
White	GND
Blue	RS485 A+
Black	RS485 B+

Table 2: Digital Output for Tilt Beam

### 3.2 SIGN CONVENTIONS

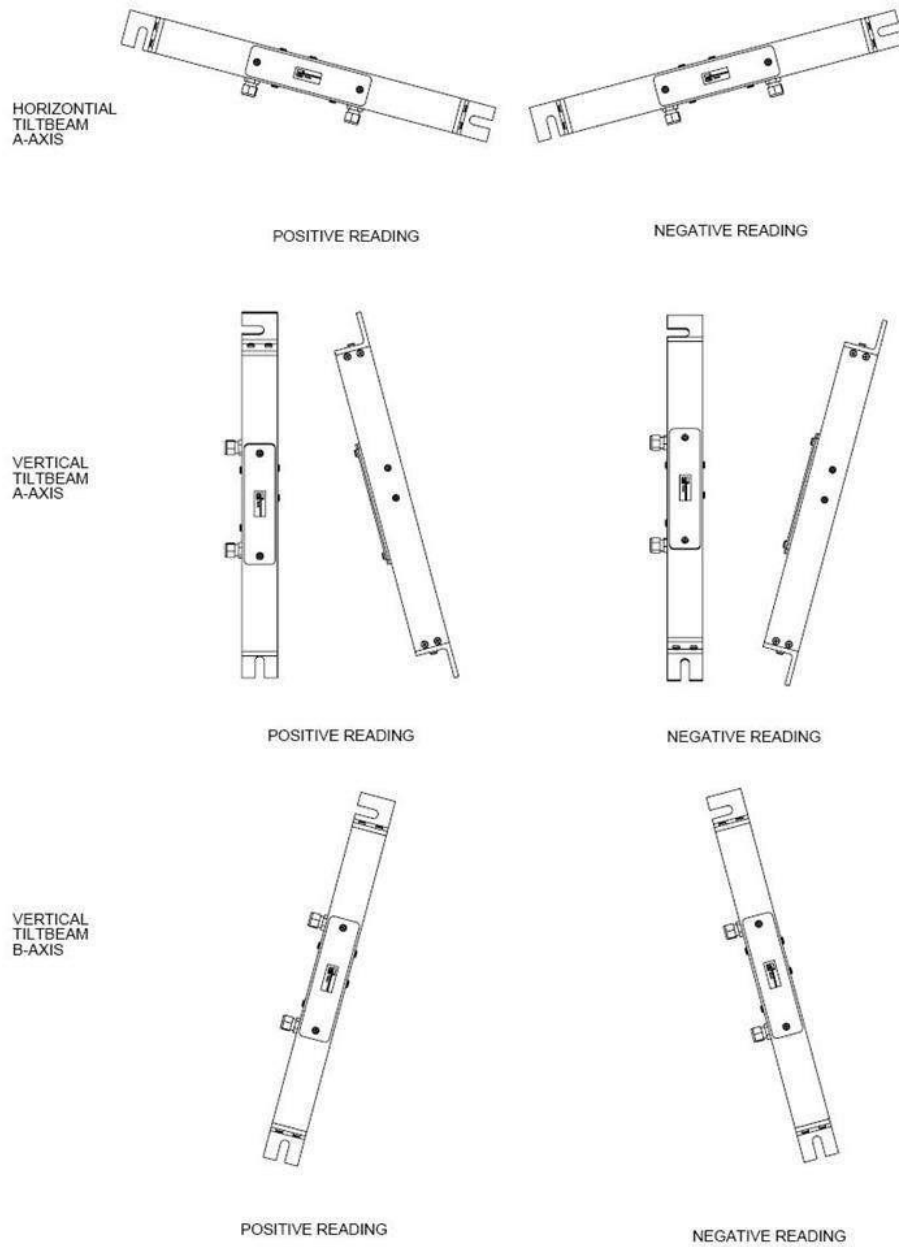

Figure 12: Multiple Tilt Beams Directional Reading

### 3.3 CALCULATION

MEMS Tilt Beams have a  $\pm 30^\circ$  sensor mounted inside the fiberglass beam. The sensor outputs  $\sin \theta$  and temperature which are read by a data logger or a handheld device. See [Table 2](#) for information on electrical connections.

Any tilt in the A axis or B axis changes the angle output of the sensor. The sign convention is as shown in section [3.1](#). Sensors output  $\sin \theta$  for each axis, which can be used to calculate the tilt angle of the structure.

The change of angle can be calculated using the following equation:

$$\Delta \sin(\theta) = \sin(\theta_c) - \sin(\theta_1)$$

Equation 1 changes in the degree of tilt angle, where:

$\Delta \sin(\theta)$  = change in degree of rotationsin

$(\theta_c)$  = current angle of rotation

$\sin(\theta_1)$  = initial angle of rotation



**NOTE:** Only read tilt meter outputs during periods of low vibration or when there are no heavy pile-driving or construction activity present.

---

## 3.4 TAKE READINGS

If possible, connect the MEMS Tilt Beam to a data logger and test to confirm full functionality before installation. Once installed, the sensors must be connected to a data logger, and a baseline reading should be taken. Subtract this value from subsequent readings to determine the change in orientation of each sensor.



**NOTE:** Ultra-Rugged Field PC2 with Digital Tilt Bus software or NAUTIZ may also be used to obtain readings.

---

Instructions for taking readings are described in the following sub - sections.

### 3.4.1 Take Initial or Baseline Reading

The MEMS Tilt Beam's initial or baseline reading ( $\sin \theta_1$ ) is the reference point from which subsequent measurements are made.

To take a MEMS Tilt Beam's initial or baseline reading, complete the following steps:

1. Record the serial number of each tilt beam.
2. Connect the cable at the end of the tilt beam string to the Affinity Logger, DT Logger or FlexDAQ data logger according to the wiring code in [Table 1](#).
3. Turn the data logger's power on and record the readings from each tilt beam in the string. See Appendix A to interpret the readings.

### 3.4.2 Take Current Readings

To take a MEMS Tilt Beam's current reading or degree of tilt ( $\sin \theta_C$ ) complete the following steps:

1. Record the serial number of each tilt beam.
2. Connect the cable at the end of the tilt beam string to the Affinity Logger, DT Logger or FlexDAQ data logger according to the wiring code in [Table 1](#).
3. Turn the data logger's power on and record the readings from each tilt beam in the string. See Appendix A to interpret the readings.

## 4 PRODUCT SPECIFICATIONS

Item	Specification
<b>Sensor</b>	
Range	$\pm 30^\circ$
Resolution	$\pm 0.0002^\circ$ (0.004 mm/m) <sup>1</sup>
Sensor	MEMS Accelerometer
Temperature Resolution	0.06°C
Operating Temperature	-40 to 60°C (-40 to 140°F)
Temperature Accuracy	$\pm 0.5^\circ\text{C}$ (0°C to 60°C)
	$\pm 1.0^\circ\text{C}$ (-40°C to 60°C)
Temperature Dependent Uncertainty	$\pm 0.016\text{ mm/m}/^\circ\text{C}$ ( $\pm 0.001^\circ/\text{C}$ ), for $\pm 5^\circ$ from vertical
	$\pm 0.033\text{ mm/m}/^\circ\text{C}$ ( $\pm 0.002^\circ/\text{C}$ ), for $\pm 15^\circ$ from vertical
Precision	$\pm 0.0013^\circ$ (0.02 mm/m) <sup>1</sup>
	$\pm 0.0005^\circ$ (0.01 mm/m) <sup>2</sup>
<b>Electrical</b>	
Supply voltage	5 to 15V DC
Signal Output	RS485 Digital bus (MODBUS RTU Protocol)
<b>Mechanical</b>	
Beam Dimension	51 x 51mm (2" x 2")
Beam Length	0.5, 1, 2, or 3m

<sup>1</sup>: 99 % Confidence Interval

<sup>2</sup>: 68% Confidence Interval

## 5 SERVICE, REPAIR AND CONTACT INFORMATION

This product does not contain any user-serviceable parts. Contact RST for product services or repairs.

- For sales information: [sales@rstinstruments.com](mailto:sales@rstinstruments.com)
- For technical support: [support@rstinstruments.com](mailto:support@rstinstruments.com)
- Website: [www.rstinstruments.com](http://www.rstinstruments.com)
- Toll free: 1-800-665-5599

### **RST Canada Office (Head Quarters)**

Address: 11545 Kingston Street, Maple Ridge, BC, Canada V2X 0Z5

Telephone: 604-540-1100

Fax: 604-540-1005

Business hours: 7:30 a.m. to 5:00 p.m. (PST) Monday to Friday, except holidays

### **RST UK Office**

Address: Unit 4 Charles Industrial Estate Stowupland Road, Stowmarket  
Suffolk, UK, IP14 5AH

Telephone: +44 1449 706680

Business hours: 9:00 a.m. to 6:30 p.m. (GMT) Monday to Friday except holidays



## APPENDIX A: INTERPRETING THE DATA

RST's MEMS Tilt Beams are identified with a serial number which can be found on the corresponding calibration certificate, provided with the instrument.

The sensing principle of the micro electro-mechanical systems (MEMS) Tilt Beam is that of an accelerometer with the sensitive axis oriented horizontally. The measured phenomenon is then the component of gravity transverse to the sensitive axis, with the formula:  $a = g \sin(\alpha)$ .

Commonly, tilt data is interpreted as linear motion – that is, rotation about a presumed radius gives an equivalent motion. In many cases, where the ultimate variable of interest is a lateral displacement at some presumed radius due to rotation, the accelerometer result can be rescaled as:

$$x = r \sin(\alpha)$$

$$= \frac{ra}{g}$$

In the case of a uniaxial MEMS tilt beam,  $r$  is the beam length. For tilt beams on rigid bodies, the radius must be chosen with some care.

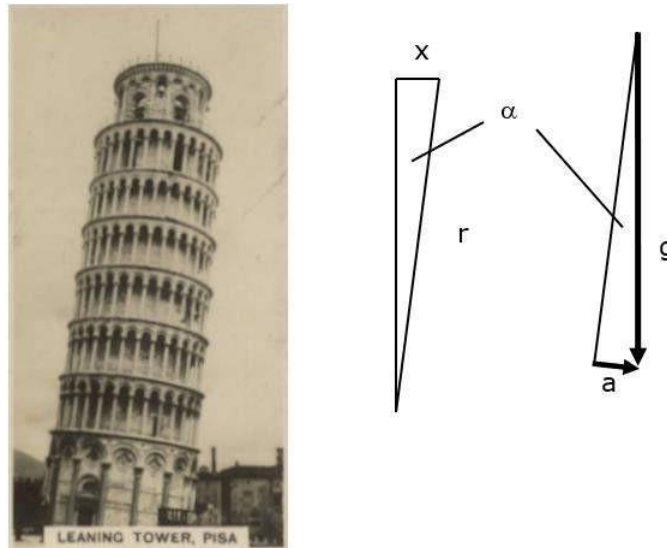

Figure 13: Tilt Beam Data Interpretation

In cases where the actual angle is needed, the arcsine function or a polynomial equivalent may be used:  $\alpha = \arcsin(a/g)$ .



**NOTE:** MEMS Tilt Beams are not designed to measure tilt on “dynamic” structures as the lateral dynamic accelerations may exceed the tilt accelerations.